

Our associates will ensure the tool works properly before you leave the store. If you experience issues with the tool while completing your project, simply bring it back to the Tool Rental Center to get a replacement. If you purchase Damage Protection at the time of your rental, you are not responsible for repair costs for tools that break due to normal use.



3-1/2 TON LOW PROFILE FLOOR JACK

Item Number W1645

OWNER'S MANUAL



Performance Tool®

▲WARNING: READ, UNDERSTAND AND FOLLOW ALL INSTRUCTIONS AND WARNINGS BEFORE OPERATING THIS TOOL. FAILURE TO DO SO MAY RESULT IN PERSONAL INJURY AND/OR PROPERTY DAMAGE AND WILL VOID WARRANTY.

PT[®]
Performance Tool

TOOL FEATURES

- | | | |
|-------------------|------------------------|-----------------------|
| 1. Steel Frame | 4. Handle Release Bolt | 7. Tool Tray |
| 2. Swivel Castors | 5. Padded Handle | 8. Lifting Arm |
| 3. Dual Pistons | 6. Handle Socket | 9. 360° Swivel Saddle |
| | | 10. Extra Wide Wheels |



SPECIFICATIONS:

Capacity.....	7,000 lbs.
Minimum Lift Height:.....	3-5/8 in.
Maximum Lift Height:.....	20-1/2 in.
Base Length:	27 in.
Base Width:	14-3/8 in.
Weight	87 lbs.
Meets or exceeds:.....	ASME PASE-2019

Specifications are subject to change without notice.

SAFETY GUIDELINES / DEFINITIONS

This instruction manual is intended for your benefit. Please read and follow the safety, installation, maintenance and troubleshooting steps described within to ensure your safety and satisfaction. The contents of this instruction manual are based upon the latest product information available at the time of publication. The manufacturer reserves the right to make product changes at any time without notice.

▲WARNING: Read and understand this entire instruction manual before attempting to assemble, install, operate or maintain this product. Failure to comply with the instructions may result in serious personal injury and/or property damage!

The following signal words are used to emphasize safety warnings that must be followed when using this product:

▲DANGER: Indicates an imminently hazardous situation that, if not avoided, *WILL* result in death or serious injury.

▲CAUTION: Indicates a potentially hazardous situation that, if not avoided, *MAY* result in minor or moderate injury.

▲WARNING: Indicates a potentially hazardous situation that, if not avoided, *COULD* result in death or serious injury.

▲NOTE: Indicates important information, which if not followed, *MAY* cause damage to equipment.

UNPACKING AND INSPECTION

After opening the carton, unpack your new product and related parts and accessories. Please inspect it carefully for any damage that may have occurred during transit. Please check it against the photograph on carton. If any parts are missing, please call customer service at 1-800-497-0552 between 6 a.m. and 5 p.m. Pacific time.

▲WARNING: *DO NOT operate this product if damaged during shipment, handling or misuse. Do not operate the product until the parts have been replaced or the fault rectified. Failure to do so may result in serious personal injury or property damage. All damaged parts must be repaired or replaced as needed prior to operating this product. Check to see that all nuts, bolts and fittings are secure before putting this product into service.*

If you have any questions, or require assistance with damaged or missing parts, please contact our customer service department at 1-800-497-0552. Please have the serial number, model number, and date of purchase available for reference when calling.

PARTS LIST

No.	Description	Qty.
1	Upper Handle Tube	1
2	Lower Handle Tube	1
3	Jack Body	1
4	Instruction Manual	1

ASSEMBLY INSTRUCTIONS

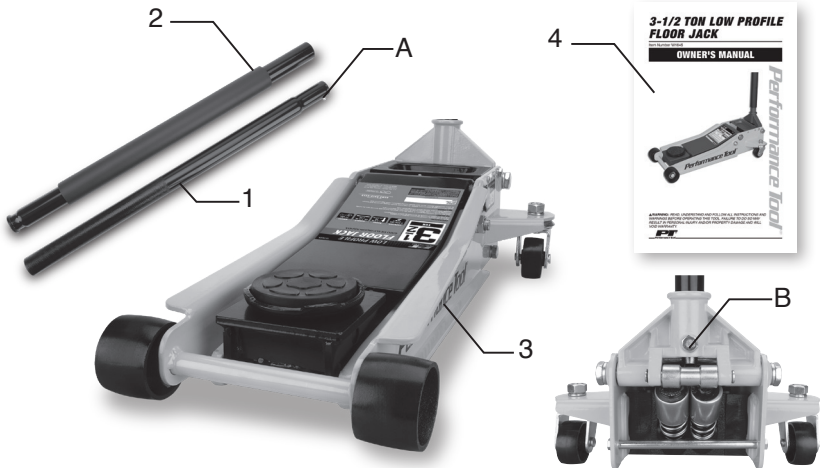

1. Press and hold the snap retainer (A) on upper handle tube and insert the handle tube into the lower handle tube. Twist the handle tube until the snap retainer protrudes through the hole in the lower handle tube.

▲CAUTION: *The handle socket may be held down by a wedge under pressure. Remove wedge carefully.*

2. The handle socket is depressed and secured for transportation. Insert the handle into the handle socket and press down on the handle. This will release the pressure allowing you to cut the cable tie and/or remove the wedge or steel hook.
3. Undo the screw (B) in the handle socket, until it no longer protrudes into the handle socket.
4. Insert the pump handle into the handle socket hole completely.
5. Ensure that the handle is correctly inserted into the socket, then tighten the handle socket screw (B). Make sure that the handle can be turned smoothly.

IMPORTANT SAFETY INFORMATION

1. Read, understand and follow all instructions before operating this device.
2. DO NOT exceed rated capacity. Overloading can cause damage to or failure of this product.
3. Use only on hard, level surface capable of sustaining the load. Use of jack on other than hard level surfaces can result in jack instability and possible loss of load.
4. Lifting device only. Immediately after lifting, support the vehicle with appropriate means. Ensure that no personnel pass underneath load until load is securely supported by jack stands.
5. DO NOT adjust safety valve.
6. Wear ANSI approved safety goggles and heavy duty work gloves during use.
7. Keep clear of load while lifting and lowering.
8. Lower load slowly. Use caution when opening the valve. Turn the handle counterclockwise slowly.
9. DO NOT use for aircraft purposes.
10. Apply parking brake and chock tires before lifting vehicle.
11. Lift vehicle only at vehicle manufacturer recommended lift locations.
12. Inspect before every use; do not use if parts are loose or damaged.
13. Do not alter this product in any way.
14. Keep your work area clean and well lit. Cluttered work areas invite accidents.
15. Keep bystanders, children, and visitors away while operating this product. Distractions can cause you to lose control.
16. Stay alert. Watch what you are doing, and use common sense when operating this product. Do not use this product while tired or under the influence of drugs, alcohol or medication.
17. Store idle jacks out of reach of children and other untrained persons. Jacks are dangerous in the hands of untrained users.
18. Jack service must be performed only by qualified repair personnel. Service or maintenance performed by unqualified personnel could result in a risk of injury.
19. When servicing this product, use only identical replacement parts - refer to attached, product-specific parts list and diagram. Follow instructions in the Care & Maintenance section of this manual. Use of unauthorized parts or failure to follow maintenance instructions may create a risk of injury and may void any applicable warranty.
20. Maintain labels and nameplates on this product. These carry important information. If unreadable or missing, contact Performance Tool for a replacement.
21. Before use, read manufacturer's instruction manual for the vehicle (or object) you will lift.
22. When lifting only one wheel, support the load immediately with one jack stand (not included) placed under the side of the vehicle being lifted. Align the saddle of the jack stand directly under the vehicle's frame or recommended lifting point.
23. When lifting the entire front end or rear end of a vehicle, support the load immediately with two jack stands. Align the saddles of the jack stands directly under the vehicle's frame or recommended lifting points. Also, adjust the jack stands to the same height.
24. Do not work under the vehicle without properly supporting the vehicle with jack stands.
25. Avoid dangerous oncoming traffic. Use the Jack as far away from the roadside as possible.
26. Industrial applications must follow OSHA requirements.
27. Do not allow anyone inside the vehicle while using the Jack. Keep all bystanders a safe distance away from the vehicle.
28. Do not support both ends of the vehicle at the same time.
29. Before lowering the jack, remove all tools and equipment from under the vehicle.
30. The warnings, precautions, and instructions discussed in this manual cannot cover all possible conditions and situations that may occur. The operator must understand that common sense and caution are factors, which cannot be built into this product, but must be supplied by the operator.

CARE AND MAINTENANCE

Monthly maintenance is recommended. Lubrication is critical to jacks as they support heavy loads. Any restriction due to dirt, rust, etc. can cause either slow movement or cause extremely rapid jerks, damaging the internal components. The following steps are designed to keep the jack maintained and operational.

1. Before each use, inspect the general condition of the jack. Check for broken, cracked, or bent parts, loose or missing parts, and any condition that may affect the proper operation of the product. Any jack that appears damaged in anyway must be removed from service. Have the problem corrected before further use. **DO NOT** use damaged equipment.
2. When jack is not in use, ram and pump piston should be in fully down position to keep their machined surfaces free from corrosion.

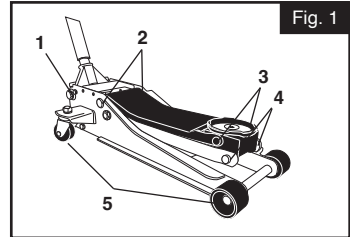

3. Keep jack clean and well lubricated at points illustrated in figure 1.
4. For best results, use only non-detergent 22 weight hydraulic jack oil for refills. Check fluid level with jack in fully down position. Fluid level should cover the top of the piston.
5. Change the hydraulic oil at least once every three years:
 - a. Fully retract the ram by turning the handle counter-clockwise.
 - b. Loosen the four top plate retaining screws and remove the top plate vertically.
 - c. Remove the fill plug on top of the cylinder.
 - d. Remove the oil with a pump or turn the unit upside down and dispose of the old hydraulic oil in accordance with local regulations.
 - e. With the jack upright, add a high quality hydraulic oil (not included) until the oil level inside the cylinder just covers the top of the piston. Be **VERY CAREFUL** not to allow dirt or foreign matter into the system. See figure 2.
 - f. Replace the fill plug, close the cover plate and re-install the screws.
 - g. Follow instruction for bleeding trapped air below.
 - h. Clean with a clean cloth using a detergent or mild solvent. Then, store the jack in a safe, dry location with the ram and pump piston in fully down position. Keep out of reach of children and other non-authorized people.

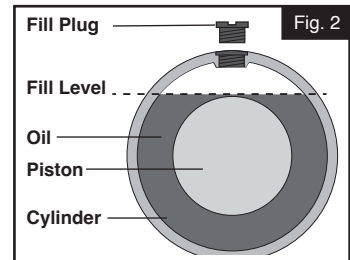

BLEEDING TRAPPED AIR:

1. Fully retract the ram by turning the handle counter-clockwise.
2. Loosen the four top plate retaining screws and remove the top plate vertically.
3. Remove the fill plug on top of the cylinder. See Figure 3. Check that the oil level inside the cylinder just covers the top of the piston.
4. Pump the handle up and down quickly 10 to 15 times to force air from the system.
5. Replace the oil filler plug and place the cover plate back into position and tighten the screws. Repeat if necessary.

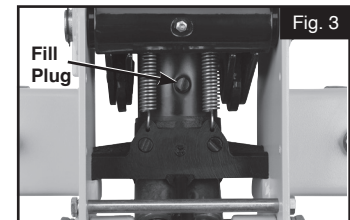

OPERATION

BEFORE USING YOUR JACK:

1. Turn the handle counter-clockwise no more than two turns to open. See Figure 4.
2. Pump jack about 6 full strokes to ensure complete distribution of hydraulic fluid.
3. Repeat above steps as needed.

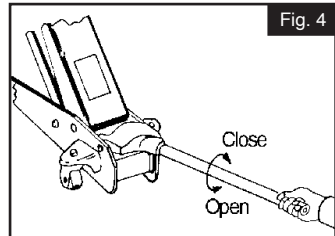

TO RAISE:

1. Park vehicle on a hard level surface safely away from oncoming traffic.
2. Place the vehicle's transmission in PARK, if equipped with an automatic, or in its lowest gear, if equipped with a manual transmission.
3. Turn off the vehicle's engine.
4. Set the vehicle's emergency brake and block the wheels that are not being lifted.
5. Refer to vehicle owner's manual for proper jacking procedures. Lift only on areas of vehicle as specified by manufacturer.
6. Make certain that load is centered on saddle.
7. Turn the handle clockwise to close.
8. Pump to raise load to desired height.
9. ALWAYS support load with jack stands. See Figure 5. Place jack stands of appropriate capacity (not included) beneath the vehicle at locations recommended by the vehicle manufacturer. DO NOT get under the vehicle without jack stands. Jacks are not designed to maintain heavy loads for long periods of time. DO NOT attempt to put jack stands simultaneously under both ends of vehicle or under one side of vehicle.

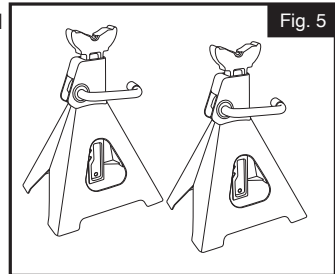

NOTE: When using two jack stands, they must be at the same height.

10. SLOWLY turn the handle counterclockwise to lower vehicle onto jack stands and remove jack.

IMPORTANT: NEVER MOVE JACK WHEN THE HANDLE IS OPERATING THE LEVER OR THE VALVE SLEEVE. DAMAGE TO THE PUMP UNIT MAY OCCUR.

TO LOWER:

1. Remove all tools, parts, etc. from under the vehicle.
2. Position the saddle under the lifting point. Turn the Handle firmly clockwise to close the valve release screw, and pump the handle to raise the vehicle slightly above the saddle(s) of the jack stands. Then, collapse and remove jack stand(s).
3. SLOWLY turn the handle counterclockwise with the handle just enough to allow controlled descent of the vehicle onto the ground. (Never more than two full turns).
4. Lower the jack completely. Then, store in a safe, dry location out of reach of children.

TROUBLESHOOTING

▲WARNING: Remove jack from service before making adjustments.

Will not lift load	●	●	●
Will not hold load			●
Will not lift to full height	●	●	
Pump feels "spongy" under load	●	●	
Handle raises under load			●
Handle lowers under load			●
<p>NOTE: <i>Problems listed above with more than one solution may have a combination of causes. Please be sure that all solutions listed for each problem have been checked to eliminate possibility of further trouble. Sometimes solutions may need to be repeated for best results.</i></p>	<p>Power unit may be low in fluid. With jack on level surface and in down position, remove filler plug and add clean hydraulic jack fluid to level of filler.</p>	<p>Power unit may be air bound. Open the release valve a minimum of 2 full turns. Pump the handle a minimum of 20 full strokes to purge air from the system.</p>	<p>Valve may not be closing completely. To seat valves: a.) Close release valve. b.) With jack in fully lowered position, manually raise lifting arm as high as possible. c.) Open release valve and allow jack to descend to lowered position.</p>
<p>Fig. 6</p> <p>Check & refill hydraulic fluid here</p> 